



**INSTITUTO DE CIENCIAS
DE LA CONSTRUCCIÓN
EDUARDO TORROJA**

C/ Serrano Galvache n. 4 28033 Madrid (Spain)
Tel.: (34) 91 302 04 40
direccion.ietcc@csic.es <https://dit.ietcc.csic.es>

European Technical Assessment

ETA 14/0374 of 21/02/2022

English translation prepared by IETcc. Original version in Spanish language

General Part

Technical Assessment Body issuing the ETA designated according to Art. 29 of Regulation (EU) 305/2011

Instituto de Ciencias de la Construcción Eduardo Torroja (IETcc)

Trade name of the construction product

Anchor Sissy Stud concrete screw

Product family to which the construction product belongs

Concrete screw of sizes 7.5, 10.5, 12.5, 14.2 and 16.5 for use in cracked and non-cracked concrete.

Manufacturer

Joker Industrial Co. Ltd.
No 10 Changbin East 7rd.
Changbin Industrial District.
Hsien Hsi. Hsiang. Changhua Hsien.
Taiwan R.O.C.
website: www.joker.com.tw

Manufacturing plants

Joker Industrial Co. Ltd.
No 10 Changbin East 7rd.
Changbin Industrial District.
Hsien Hsi. Hsiang. Changhua Hsien.
Taiwan R.O.C.

This European Technical Assessment contains

22 pages including 4 annexes which form an integral part of this assessment.

This European Technical Assessment is issued in accordance with regulation (EU) No 305/2011, on the basis of

European Technical Assessment EAD 330232-01-0601 "Mechanical Fasteners for use in concrete", ed. December 2019

This ETA replaces

ETA 14/0374 version 2 issued on 08/03/2019

English translation prepared by IETcc

This European Technical Assessment is issued by the Technical Assessment Body in its official language. Translations of this European Technical Assessment in other languages shall fully correspond to the original issued document and should be identified as such.

This European Technical Assessment may be withdrawn by the issuing Technical Assessment Body, in particular pursuant to information by the Commission according to article 25 (3) of Regulation (EU) No 305/2011.

English translation prepared by IETcc

SPECIFIC PART

1. Technical description of the product

The Sissy Stud concrete screw is an anchor made of carbon steel. The anchor is made in sizes 7.5, 10.5, 12.5, 14.2 and 16.5, and is screwed into a predrilled cylindrical drill hole. The special thread of the anchor cuts an internal thread into the member while setting. The anchorage is characterised by mechanical interlock in the special thread.

The product and its installation description are shown in annexes A.

2. Specification of the intended use in accordance with the applicable European Assessment Document.

The performances given in section 3 are only valid if the anchor is used in compliance with the specifications and conditions given in annex B.

The verifications and assessment methods on which this European Technical Assessment is based lead to the assumption of a working life of the anchor of at least 50 years. The indications given on the working life cannot be interpreted as a guarantee given by the producer, but are to be regarded only as a means to choosing the right products in relation to the expected economically reasonable working life of the works.

3. Performance of the product and references to the methods used for its assessment

3.1 Mechanical resistance and stability (BWR 1)

Essential characteristic	Performance
Static or quasi static actions	See annexes C1 to C5
Essential characteristic and displacements for seismic performance categories C1 and C2	See annexes C6 and C7

3.2 Safety in case of fire (BWR 2)

Essential characteristic	Performance
Reaction to fire	Anchorage satisfies requirements for class A1
Resistance to fire	See annex D

4. Assessment and verification of constancy of performance (hereinafter AVCP) system applied, with reference to its legal base

The applicable European legal act for the system of Assessment and Verification of Constancy of Performances (see annex V of Regulation (EU) No 305/2011) is 96/582/EC.

The system to be applied is 1.

English translation prepared by IETcc

5. Technical details necessary for the implementation of the AVCP system, as provided for in the applicable European Assessment Document.

The technical details necessary for the implementation of the AVCP system are laid down in the quality plan deposited at Instituto de Ciencias de la Construcción Eduardo Torroja.



Instituto de Ciencias de la Construcción Eduardo Torroja
CONSEJO SUPERIOR DE INVESTIGACIONES CIENTÍFICAS

C/ Serrano Galvache n.º 4. 28033 Madrid.
Tel: (+34) 91 302 04 40
<https://dit.ietcc.csic.es>



On behalf of the Instituto de Ciencias de la Construcción Eduardo Torroja
Madrid, 21st of February 2022



Director IETcc-CSIC

English translation prepared by IETcc

Product and identification

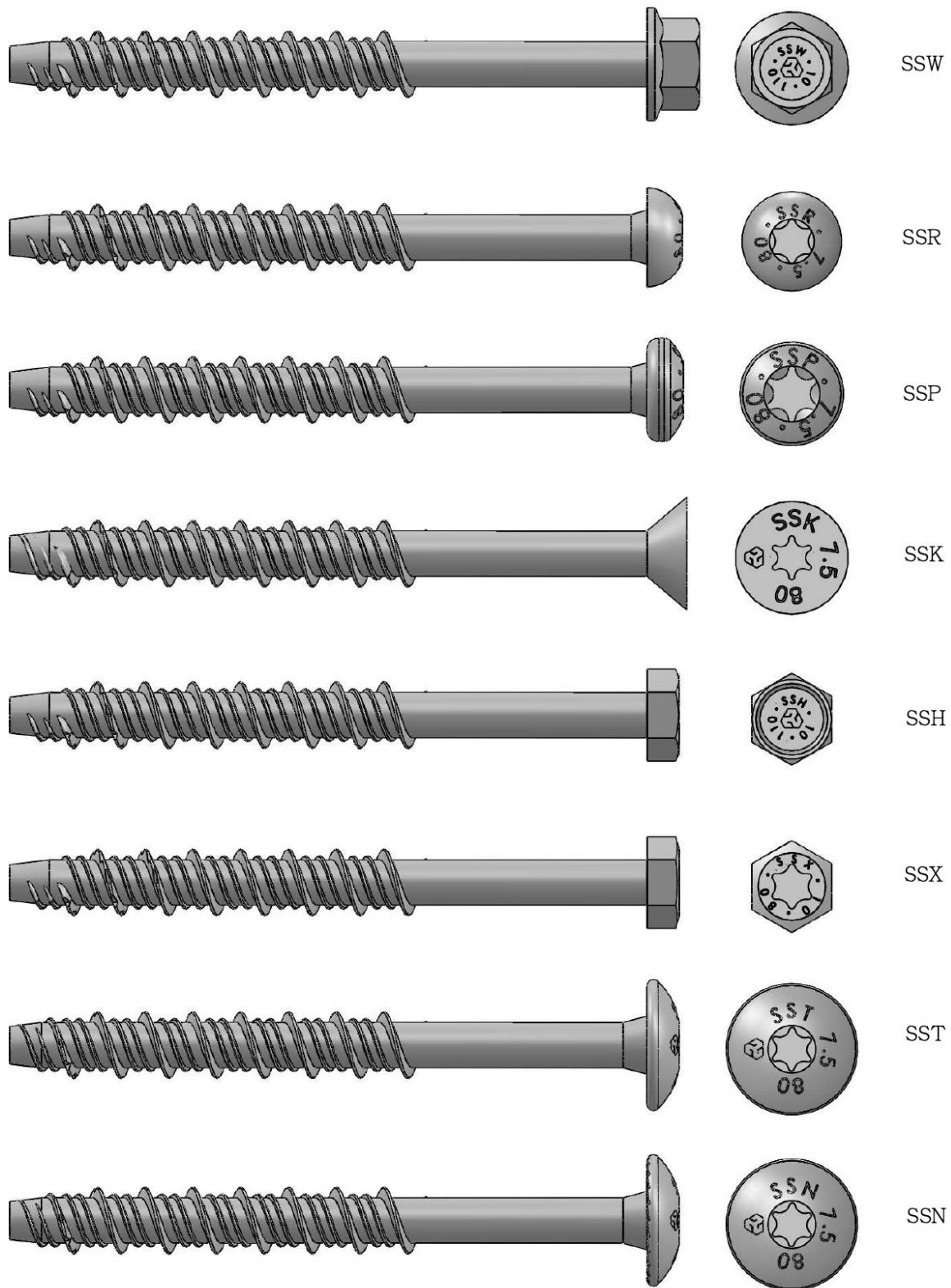









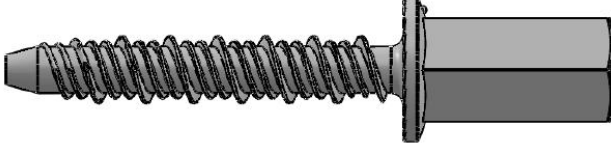
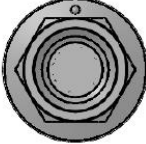
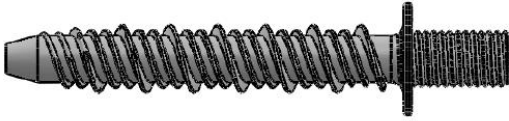
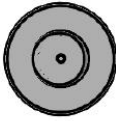

Sissy Stud concrete screw

Product description

Identification

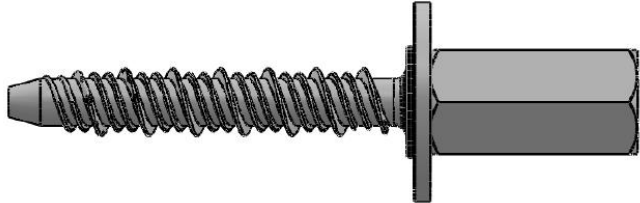
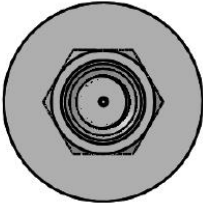
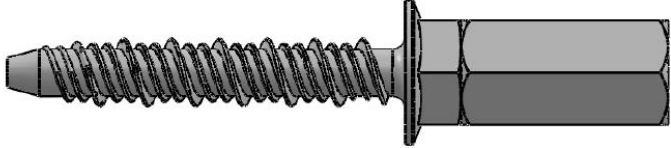
Annex A1

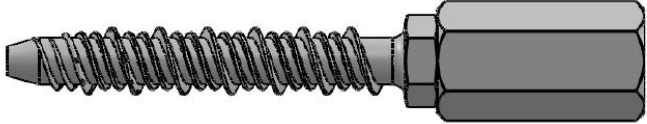
English translation prepared by IETcc

		SSD
		SSI
		SSF
		SSO
		SSU
		SSG
		SSQ
		SSV

Sissy Stud concrete screw	Annex A2
Product description	
Identification	

English translation prepared by IETcc

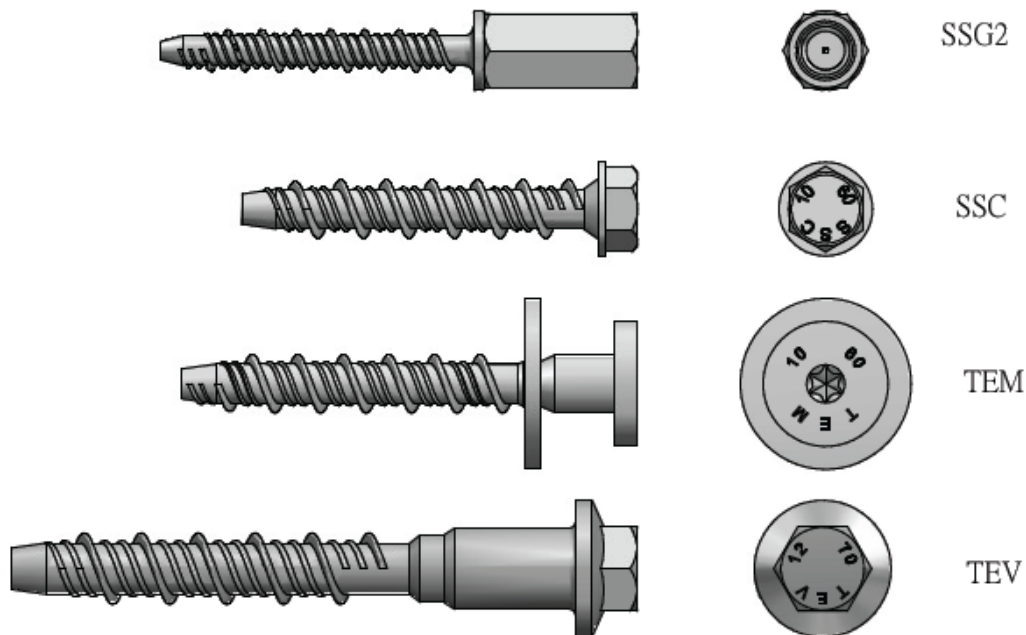

Marking/Identification on anchor:

- Company logo
- Outer diameter
- Length
- Anchor type:
 - Hex head with washer SSW
 - Round head SSR
 - Pan head SSP
 - Countersunk head SSK
 - Hex head SSH
 - Hex head, hexalobular recess SSX
 - Truss head SST
 - Truss head with underhead ribs SSN
 - Connection thread with hexagon drive SSD
 - Internal thread SSI
 - Flat washer head with connection thread SSF
 - Hex washer head with connection thread SSO
 - Hex head with connection thread SSU
 - SSF flex with coupler nut SSG
 - SSO flex with coupler nut SSQ
 - SSU flex with coupler nut SSV
 - SSG flex without washer SSG2
 - Hexagon head with bevelled shoulder SSC
 - Special head with TEM style TEM
 - Special head with TEV style TEV

Sissy Stud concrete screw	Annex A3
Product description	
Identification	

English translation prepared by IETcc

Table A1: Materials

Item	Designation	Sissy Stud concrete screw
1	Anchor Body	Carbon steel wire rod cold forged. Allowed coatings: <ul style="list-style-type: none">• Zinc plated ISO 4042• Silver ruspert• Zinc flake EN 10683• Mechanical plated.

Sissy Stud concrete screw	Annex A4
Product description	
Identification	

English translation prepared by IETcc

Installed condition

- h_{ef} : Effective anchorage depth
- h_1 : Depth of drilled hole
- h_{nom} : Overall anchor embedment depth in the concrete
- h_{min} : Minimum thickness of concrete member
- t_{fix} : Thickness of fixture
- d_o : Nominal diameter of drill bit
- d_f : Diameter of clearance hole in fixture

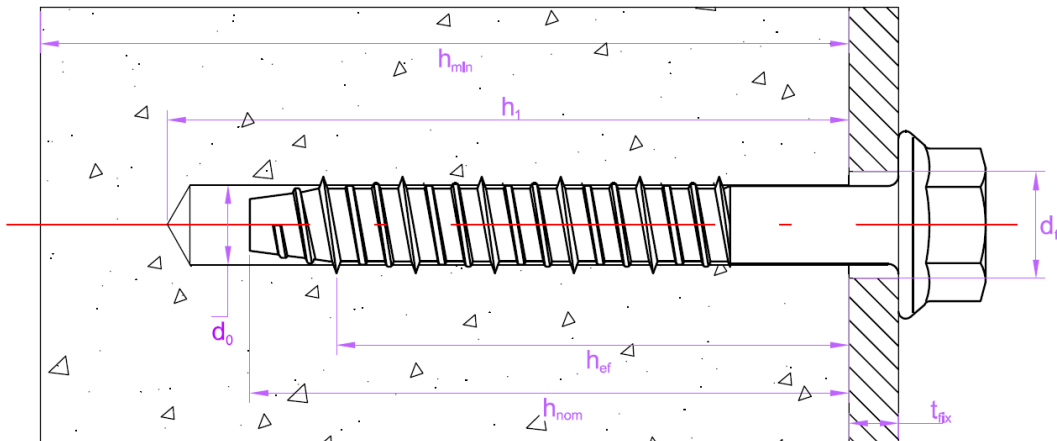

Drawing A1. Installed condition for anchors SSW, SSR, SSP, SSK, SSH, SSX, SST, SSN and SSC.

Sissy Stud concrete screw	Annex A5
Product description	
Installed condition	

English translation prepared by IETcc

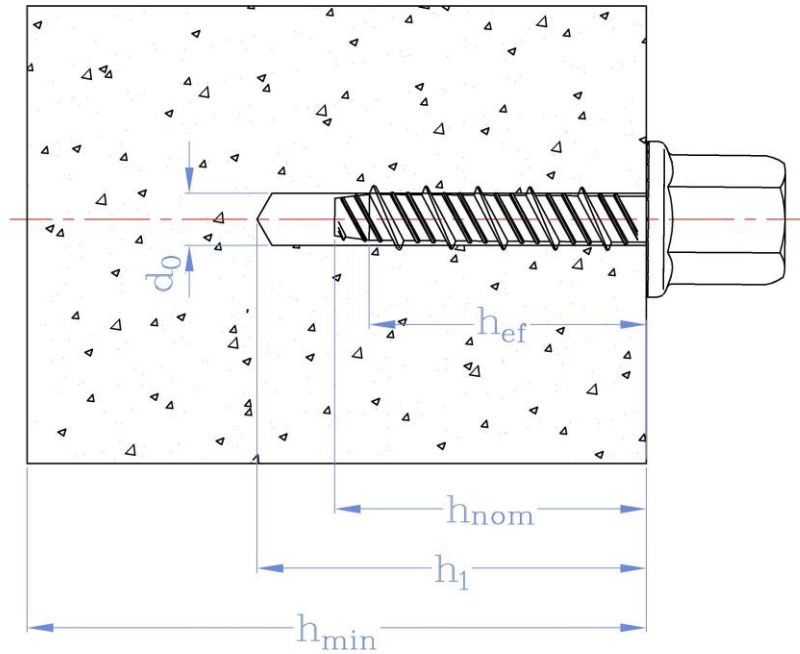

Drawing A2. Installed condition for anchors SSD, SSI, SSF, SSO, SSU, SSG, SSQ, SSV, SSG2, TEM and TEV.

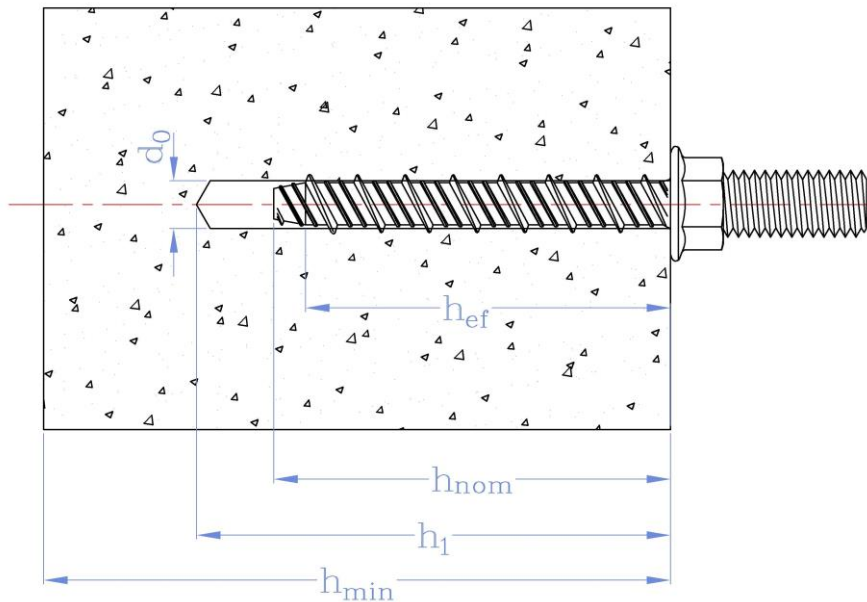

Drawing A3. Installed condition for anchors SSD, SSI, SSF, SSO, SSU, SSG, SSQ, SSV, SSG2, TEM and TEV.

<p>Sissy Stud concrete screw</p>	<p>Annex A6</p>
<p>Product description</p>	
<p>Installed condition</p>	

Intended use

Anchorage subjected to:

- Static or quasi static loads: all sizes and embedment depths.
- Seismic actions for performances C1 and C2 as per table below

Size	7.5		10.5		12.5		14.2		16.5		
h_{nom}	40	55	50	60	60	70	85	75	105	75	110
C1				✓			✓				✓
C2							✓				✓

Base materials:

- Reinforced and unreinforced normal weight concrete without fibers according to EN 206:2013 + A1:2016.
- Strength classes C20/25 to C50/60 according to EN 206:2013 + A1:2016.
- Cracked and uncracked concrete.

Use conditions (environmental conditions):

- The anchor shall be used in dry internal conditions.
- The anchor may be used for anchorages with requirements related to resistance to fire.

Design:

- Anchorages are designed under the responsibility of an engineer experienced in anchorages and concrete.
- Verifiable calculation rules and drawings are prepared taking into account of the loads to be attached. The position of the anchor is indicated on the design drawings (e.g. position of the anchor relative to reinforcement or to supports, etc.)
- Anchorages under static or quasi-static loads are designed for design Method A in accordance with EN 1992-4:2018
- Anchorages under seismic actions are designed in accordance with EN 1992-4:2018. Anchorages shall be positioned outside of critical regions (e.g. plastic hinges) of the concrete structure. Fastening in stand-off installation or with grout layer are not allowed.
- Anchorages under fire exposure are designed in accordance with EN 1992-4:2018. It must be ensured that local spalling of the concrete cover does not occur.
- Shear assessment only covers the shear force induced by the fixed piece, i.e. the piece located between the anchor head and the concrete block (piece contained in t_{fix} , see Drawing A1).

Installation:

- Hammer drilling only.
- Anchor installation carried out by appropriately qualified personal and under the supervision of the person responsible for technical matters of the site.
- In case of aborted hole: new drilling at a minimum distance away of twice the depth of aborted hole or smaller distance if the aborted hole is filled with high strength mortar and if under shear or oblique tension load it is not the direction of the load application.
- After installation further turning of the anchor is not possible. The head of the anchor is supported on the fixture, as it is shown in Drawing A1, and it must not be damaged.

Sissy Stud concrete screw

Intended use

Specifications

Annex B1

English translation prepared by IETcc

Table B1: Installation parameters

Installation parameters			Performance						
			SS 7.5		SS 10.5		SS 12.5		
h_{nom}	Overall anchor embedment depth in the concrete:	[mm]	40	55	50	60	60	70	85
d_0	Nominal diameter of drill bit:	[mm]	6		8		10		
d_f	Diameter of clearance hole in fixture:	[mm]	9		12		14		
d_s	Outer diameter of the thread	[mm]	7.5		10.5		12.5		
h_{min}	Minimum thickness of concrete member:	[mm]	100	100	100	100	100	105	130
h_1	Depth of drilled hole:	[mm]	50	65	60	70	70	85	100
h_{ef}	Effective anchorage depth:	[mm]	29	42	37	45	44	52	65
T_{ins}	Installation torque	[Nm]	15		25		50		
t_{fix}	Thickness of fixture	[mm]	L-40	L-55	L-50	L-60	L-60	L-70	L-85
s_{min}	Minimum allowable spacing:	[mm]	35	45	35	50	50	60	70
c_{min}	Minimum allowable edge distance:	[mm]	35	45	35	50	40	60	60

Installation parameters			Performance			
			SS 14.2		SS 16.5	
h_{nom}	Overall anchor embedment depth in the concrete:	[mm]	75	105	75	110
d_0	Nominal diameter of drill bit:	[mm]	12		14	
d_f	Diameter of clearance hole in fixture:	[mm]	16		18	
d_s	Outer diameter of the thread	[mm]	14.2		16.5	
h_{min}	Minimum thickness of concrete member:	[mm]	120	170	120	175
h_1	Depth of drilled hole:	[mm]	90	120	90	130
h_{ef}	Effective anchorage depth:	[mm]	57	82	56	86
T_{ins}	Installation torque	[Nm]	60		80	
t_{fix}	Thickness of fixture	[mm]	L-75	L-105	L-75	L-110
s_{min}	Minimum allowable spacing:	[mm]	70	70	75	100
c_{min}	Minimum allowable edge distance:	[mm]	45	45	45	100

Sissy Stud concrete screw

Performances

Installation parameters and installation procedure

Annex B2

English translation prepared by IETcc

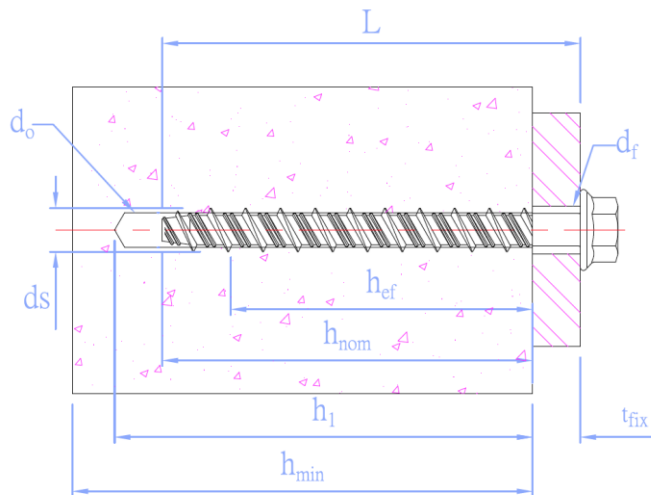

Drawing B1. Installed condition for anchors SSW, SSR, SSP, SSK, SSH, SSX, SST, SSN and SSC.

Installation process

	<p>1. DRILL Drill a hole into the base material of correct diameter and depth by using a carbide drill bit in rotary plus hammer mode.</p>
	<p>2. BLOW and CLEAN Remove dust and debris from hole and loose particles left from drilling by using hand pump, compressed air or vacuum.</p>
	<p>3. INSTALL Hold screw anchor perpendicular direction into the base material through fixtures.</p>
	<p>4. APPLIE TORQUE Select a power impact wrench or a torque wrench(e.g: Bosch GDS 18E, power input: 500 W; torque: 50-250 Nm). Power impact wrench does not exceed over torque T_{inst}.</p>
	<p>5. CHECK The head must be undamaged and in contact with the fixture. When screw head attach fixture or concrete surface firmly, furthre turning of the head is unnecessary.</p>

Sissy Stud concrete screw

Performances

Installation parameters and installation procedure

Annex B3

English translation prepared by IETcc

Table C1: Characteristic values to tension loads of design method A

Characteristic values of resistance to tension loads of design method A			Performance						
			SS 7.5		SS 10.5		SS 12.5		
h_{nom}	Overall anchor embedment depth in the concrete:	[mm]	40	55	50	60	60	70	85
Tension loads: steel failure									
$N_{Rk,s}$	Tension steel characteristic resistance:	[kN]	18.7		32.7		51.2		
γ_{Ms}	Partial safety factor: ¹⁾	[-]	1.5		1.5		1.5		
Tension loads: pull-out failure in concrete									
$N_{Rk,p,ucr}$	Tension characteristic resistance in C20/25 uncracked concrete:	[kN]	6.0	9.0	²⁾	12.0	²⁾	20	²⁾
$\Psi_{c,ucr}$	C30/37	[-]	1.16	1.22	1.16	1.08	1.15	1.04	1.09
$\Psi_{c,ucr}$	C40/45	[-]	1.28	1.41	1.28	1.15	1.27	1.07	1.15
$\Psi_{c,ucr}$	C50/60	[-]	1.39	1.55	1.39	1.19	1.37	1.09	1.21
$N_{Rk,p,cr}$	Tension characteristic resistance in C20/25 cracked concrete:	[kN]	3.0	6.0	6.5	9.0	²⁾	12	²⁾
$\Psi_{c,cr}$	C30/37	[-]	1.17	1.22	1.16	1.22	1.14	1.22	1.18
$\Psi_{c,cr}$	C40/45	[-]	1.30	1.41	1.29	1.41	1.25	1.41	1.33
$\Psi_{c,cr}$	C50/60	[-]	1.42	1.55	1.40	1.55	1.34	1.55	1.46
Tension loads: concrete cone and splitting failure									
γ_{ins}	Installation safety factor: ¹⁾	[-]	1.2	1.2	1.2	1.2	1.2	1.2	1.0
h_{ef}	Effective embedment depth:	[mm]	29	42	37	45	44	52	65
$k_{ucr,N}$	Factor for uncracked concrete:	[-]	11.0						
$k_{cr,N}$	Factor for cracked concrete:	[-]	7.7						
$s_{cr,N}$	Critical spacing:	[mm]	3.0 x h_{ef}						
$c_{cr,N}$	Critical edge distance:	[mm]	1.5 x h_{ef}						
$s_{cr,sp}$	Critical spacing (splitting):	[mm]	3.0 x h_{ef}						
$c_{cr,sp}$	Critical edge distance (splitting):	[mm]	1.5 x h_{ef}						

¹⁾ In absence of other national regulations

²⁾ Pull-out failure is not decisive

Sissy Stud concrete screw

Performances

Characteristic values for tension loads

Annex C1

English translation prepared by IETcc

Characteristic values of resistance to tension loads of design method A			Performance			
			SS 14.2		SS 16.5	
h_{nom}	Overall anchor embedment depth in the concrete:	[mm]	75	105	75	110
Tension loads: steel failure						
$N_{Rk,s}$	Tension steel characteristic resistance:	[kN]	80.6		115.9	
γ_{Ms}	Partial safety factor: ¹⁾	[-]	1.5		1.5	
Tension loads: pull-out failure in concrete						
$N_{Rk,p,ucr}$	Tension characteristic resistance in C20/25 uncracked concrete:	[kN]	²⁾	²⁾	²⁾	40
$\psi_{c,ucr}$	C30/37	[-]	1.10	1.09	1.13	1.04
$\psi_{c,ucr}$	C40/45	[-]	1.17	1.16	1.24	1.07
$\psi_{c,ucr}$	C50/60	[-]	1.23	1.21	1.33	1.09
$N_{Rk,p,cr}$	Tension characteristic resistance in C20/25 cracked concrete:	[kN]	²⁾	²⁾	²⁾	30
$\psi_{c,cr}$	C30/37	[-]	1.11	1.08	1.14	1.12
$\psi_{c,cr}$	C40/45	[-]	1.19	1.15	1.26	1.23
$\psi_{c,cr}$	C50/60	[-]	1.26	1.20	1.35	1.30
Tension loads: concrete cone and splitting failure						
γ_{ins}	Installation safety factor: ¹⁾	[-]	1.2	1.0	1.2	1.0
h_{ef}	Effective embedment depth:	[mm]	57	82	56	86
$k_{ucr,N}$	Factor for uncracked concrete:	[-]	11.0			
$k_{cr,N}$	Factor for cracked concrete:	[-]	7.7			
$s_{cr,N}$	Critical spacing:	[mm]	3.0 x h_{ef}			
$c_{cr,N}$	Critical edge distance:	[mm]	1.5 x h_{ef}			
$s_{cr,sp}$	Critical spacing (splitting):	[mm]	3.0 x h_{ef}			
$c_{cr,sp}$	Critical edge distance (splitting):	[mm]	1.5 x h_{ef}			
¹⁾ In absence of other national regulations ²⁾ Pull-out failure is not decisive						
Sissy Stud concrete screw					Annex C2	
Performances						
Characteristic values for tension loads						

English translation prepared by IETcc

Table C2: Displacements under tension loads for Sissy Stud concrete screw

Characteristic values of displacements under tension loads of design method A		Performance							
		SS 7.5		SS 10.5		SS 12.5			
h_{nom}	Overall anchor embedment depth in the concrete: [mm]	40	55	50	60	60	70	85	
Displacements under tension loads in uncracked concrete									
N	Service tension load in uncracked concrete C20/25 to C50/60: [kN]	2.4	3.6	4.4	4.8	5.7	9.5	12.3	
$\bar{\delta}_{N0}$	Short term displacement under tension loads: [mm]	0.06	0.40	0.08	0.40	0.09	0.40	0.12	
$\bar{\delta}_{N\infty}$	Long term displacement under tension loads: [mm]	0.30	1.00	0.35	1.10	0.40	1.40	0.55	
Displacements under tension loads in cracked concrete									
N	Service tension load in cracked concrete C20/25 to C50/60: [kN]	1.2	2.4	2.5	3.6	4.0	5.7	8.6	
$\bar{\delta}_{N0}$	Short term displacement under tension loads: [mm]	0.10	0.60	0.12	0.70	0.15	0.50	0.17	
$\bar{\delta}_{N\infty}$	Long term displacement under tension loads: [mm]	1.10	1.40	1.20	1.20	1.25	1.40	0.55	

Characteristic values of displacements under tension loads of design method A		Performance			
		SS 14.2		SS 16.5	
h_{nom}	Overall anchor embedment depth in the concrete: [mm]	75	105	75	110
Displacements under tension loads in uncracked concrete					
N	Service tension load in uncracked concrete C20/25 to C50/60: [kN]	11.3	18.1	8.2	19.0
$\bar{\delta}_{N0}$	Short term displacement under tension loads: [mm]	0.08	0.10	0.10	0.90
$\bar{\delta}_{N\infty}$	Long term displacement under tension loads: [mm]	0.40	0.40	0.45	1.40
Displacements under tension loads in cracked concrete					
N	Service tension load in cracked concrete C20/25 to C50/60: [kN]	7.7	13.3	5.7	11.9
$\bar{\delta}_{N0}$	Short term displacement under tension loads: [mm]	0.13	0.15	0.20	0.60
$\bar{\delta}_{N\infty}$	Long term displacement under tension loads: [mm]	1.25	1.35	1.32	1.20

Sissy Stud concrete screw	Annex C3
Performances	
Displacement under tension loads	

English translation prepared by IETcc

Table C3: Characteristic values to shear loads of design method A

Characteristic values of resistance to shear loads		Performance						
		SS 7.5		SS 10.5		SS 12.5		
h_{nom}	Overall anchor embedment depth in the concrete: [mm]	40	55	50	60	60	70	85
Shear loads: steel failure without lever arm								
$V_{Rk,s}$	Shear steel characteristic resistance: [kN]	9.3	7.5	16.3		25.6		
k_7	k_7 factor:	0.8		0.8		0.8		
γ_{Ms}	Partial safety factor: *)	1.25		1.25		1.25		
Shear loads: steel failure with lever arm								
$M^0_{Rk,s}$	Characteristic bending moment: [Nm]	15.2		35.3		69.3		
γ_{Ms}	Partial safety factor: *)	1.25		1.25		1.25		
Shear loads: concrete pryout failure								
k_8	k_8 factor: [-]	0.8	1.0	1.2	1.0	1.0	1.0	1.0
γ_{inst}	Installation safety factor: *)	1.0	1.5	1.0	1.5	1.0	1.5	1.0
Shear loads: concrete edge failure								
l_f	Effective anchorage depth under shear loads: [mm]	29	42	37	45	44	52	65
d_{nom}	Nominal outer diameter of screw: [mm]	6	6	8	8	10	10	10
γ_{inst}	Installation safety factor: *)	1.2	1.5	1.2	1.5	1.2	1.5	1.0

*) In absence of other national regulations

Characteristic values of resistance to shear loads		Performance			
		SS 14.2		SS 16.5	
h_{nom}	Overall anchor embedment depth in the concrete: [mm]	75	105	75	110
Shear loads: steel failure without lever arm					
$V_{Rk,s}$	Shear steel characteristic resistance: [kN]	40.3		57.9	
k_7	k_7 factor:	0.8		0.8	
γ_{Ms}	Partial safety factor: *)	1.25		1.25	
Shear loads: steel failure with lever arm					
$M^0_{Rk,s}$	Characteristic bending moment: [Nm]	137.1		235.9	
γ_{Ms}	Partial safety factor: *)	1.25		1.25	
Shear loads: concrete pryout failure					
k_8	k_8 factor: [-]	1.5		1.6	2.0
γ_{inst}	Installation safety factor: *)	1.25		1.0	1.5
Shear loads: concrete edge failure					
l_f	Effective anchorage depth under shear loads: [mm]	57	82	56	86
d_{nom}	Nominal outer diameter of screw: [mm]	12	12	14	14
γ_{inst}	Installation safety factor: *)	1.2	1.0	1.2	1.5

*) In absence of other national regulations

9Sissy Stud concrete screw	Annex C4
Performances	
Characteristic values for shear loads	

English translation prepared by IETcc

Table C4: Displacements under shear loads

Characteristic values of displacements under shear loads of design method A			Performances						
			SS 7.5		SS 10.5		SS 12.5		
h_{nom}	Overall anchor embedment depth in the concrete:	[mm]	40	55	50	60	60	70	85
Displacements under shear loads in uncracked concrete									
V	Service shear load in cracked and uncracked concrete C20/25 to C50/60:	[kN]	3.0	3.6	4.4	4.8	5.7	9.5	12.3
δ_{V0}	Short term displacement under shear loads:	[mm]	0.47	0.4	0.50	0.40	0.40	0.40	0.80
$\delta_{V\infty}$	Long term displacement under shear loads:	[mm]	0.70	1.0	0.75	1.10	0.60	1.40	1.20
Displacements under shear loads in cracked concrete									
V	Service shear load in cracked and uncracked concrete C20/25 to C50/60:	[kN]	2.1	2.4	3.1	3.6	4.0	5.7	8.6
δ_{V0}	Short term displacement under shear loads:	[mm]	0.40	0.60	0.45	0.70	0.50	0.50	0.6
$\delta_{V\infty}$	Long term displacement under shear loads:	[mm]	0.60	1.40	0.67	1.20	0.75	1.40	0.90

Characteristic values of displacements under shear loads of design method A			Performances			
			SS 14.2		SS 16.5	
h_{nom}	Overall anchor embedment depth in the concrete:	[mm]	75	105	75	110
Displacements under shear loads in uncracked concrete						
V	Service shear load in cracked and uncracked concrete C20/25 to C50/60:	[kN]	8.4	17.4	8.2	19.0
δ_{V0}	Short term displacement under shear loads:	[mm]	1.00	1.10	0.55	0.90
$\delta_{V\infty}$	Long term displacement under shear loads:	[mm]	1.50	1.80	0.82	1.4
Displacements under shear loads in cracked concrete						
V	Service shear load in cracked and uncracked concrete C20/25 to C50/60:	[kN]	5.9	12.2	5.7	11.9
δ_{V0}	Short term displacement under shear loads:	[mm]	0.85	1.00	0.50	0.60
$\delta_{V\infty}$	Long term displacement under shear loads:	[mm]	1.20	1.50	0.75	1.20

Information for design of anchorages under shear loads:

The conditions given in EN 1992-4:2018 are not fulfilled because the diameter of the clearance hole in the fixture (see "Installation parameters" table B1) is greater than the values given in EN 1992-4 Table 6.1 for the corresponding diameter of the anchor. Therefore, condition EN 1992-4 6.2.2.2(1) a) 2) is not valid for shear steel failure for anchors groups ($n > 1$). Consequently, it is assumed that for the proof of steel failure, only two anchors of a group are effective and take up shear forces."

Sissy Stud concrete screw

Performances

Displacements under shear loads

Annex C5

English translation prepared by IETcc

Table C5: Essential characteristics for seismic performance category C1

Essential characteristics for seismic performance category C1			Performances		
			10.5	12.5	16.5
h_{nom}	Overall anchor embedment depth in the concrete:	[mm]	60	85	110
Steel failure for tension and shear loads					
$N_{Rk,s,C1}$	Characteristic resistance:	[kN]	32.7	51.2	115.9
γ_{Ms}	Partial safety factor ¹⁾ :	[-]	1.5	1.5	1.5
$V_{Rk,s,C1}$	Characteristic resistance:	[kN]	16.3	24.3	57.9
γ_{Ms}	Partial safety factor ¹⁾ :	[-]	1.25	1.25	1.25
Pull out failure					
$N_{Rk,p,C1}$	Characteristic resistance in cracked concrete:	[kN]	9.0	24.0	30.0
γ_{inst}	Robustness:	[-]	1.8	1.8	1.5
Concrete cone failure					
h_{ef}	Effective embedment depth:	[mm]	45	65	86
$s_{cr,N}$	Concrete Spacing:	[mm]	135	195	258
$c_{cr,N}$	cone failure Edge distance:	[mm]	67	98	129
γ_{inst}	Installation safety factor:	[-]	1.2	1.0	1.0
Concrete pry-out failure					
k_8	Pry-out factor:	[-]	1.0	0.9	1.5
γ_{inst}	Installation safety factor:	[-]	1.2	1.0	1.0
Concrete edge failure					
$l_f = h_{ef}$	Effective length of fastener under shear loads:	[mm]	45	65	86
d_{nom}	Nominal outer diameter of screw:	[mm]	8	10	14
γ_{inst}	Installation safety factor:	[-]	1.0	1.0	1.0

¹⁾ In absence of other national regulations

Sissy Stud concrete screw	Annex C6
Performances	
Essential characteristics for seismic performance category C1	

English translation prepared by IETcc

Table C6: Essential characteristics for seismic performance category C2

Essential characteristics for seismic performance category C2			Performances	
			12.5	16.5
h_{nom}	Overall anchor embedment depth in the concrete:	[mm]	85	110
Steel failure for tension and shear loads				
$N_{Rk,s,C2}$	Characteristic resistance:	[kN]	51.2	115.9
γ_{Ms}	Partial safety factor ¹⁾ :	[-]	1.5	1.5
$V_{Rk,s,C2}$	Characteristic resistance:	[kN]	16.1	41.1
γ_{Ms}	Partial safety factor ¹⁾ :	[-]	1.25	1.25
Pull out failure				
$N_{Rk,p,C2}$	Characteristic resistance in cracked concrete:	[kN]	11.0	9.6
γ_{inst}	Robustness:	[-]	1.8	1.5
Concrete cone failure				
h_{ef}	Effective embedment depth:	[mm]	65	86
$s_{cr,N}$	Concrete Spacing:	[mm]	195	258
$c_{cr,N}$	cone failure Edge distance:	[mm]	98	129
γ_{inst}	Installation safety factor:	[-]	1.0	1.0
Concrete pry-out failure				
k_8	Pry-out factor:	[-]	0.92	1.5
γ_{inst}	Installation safety factor:	[-]	1.0	1.0
Concrete edge failure				
$l_f = h_{ef}$	Effective length of fastener under shear loads:	[mm]	65	86
d_{nom}	Nominal outer diameter of screw:	[mm]	10.0	14.0
γ_{inst}	Installation safety factor:	[-]	1.0	1.0
Displacements				
$\bar{\delta}_{N,C2} (DLS)$	Displacement at	[mm]	0.35	0.73
$\bar{\delta}_{V,C2} (DLS)$	Damage Limitation State: ²⁾	[mm]	5.16	5.67
$\bar{\delta}_{N,C2} (ULS)$	Displacement at	[mm]	1.11	2.06
$\bar{\delta}_{V,C2} (ULS)$	Ultimate Limitation State: ²⁾	[mm]	7.90	7.90

DLS: Damage Limitation State: see EN 1992-4, 2.2.1)

ULS: Ultimate Limitation State: see EN 1992-4 2.2.1)

¹⁾ In absence of other national regulations

²⁾ The listed displacements represent mean values

Sissy Stud concrete screw

Performances

Essential characteristics for seismic performance category C2

Annex C7

English translation prepared by IETcc

Table D1: Characteristic values to fire resistance

Fire resistance duration = 30 minutes		SS 7.5	SS 10.5	SS 12.5	SS 16.5
Tension loads, steel failure					
$N_{Rk,s,fi,30}$	Characteristic resistance [kN]	0.23	0.61	1.28	2.90
Pull-out failure					
$N_{Rk,p,fi,30}$	Character. resistance in concrete C20/25 to C50/60 [kN]	1.50	2.25	3.00	7.50
Concrete cone failure **)					
$N_{Rk,c,fi,30}$	Character. resistance in concrete C20/25 to C50/60 [kN]	2.06	2.45	3.51	12.35
Shear loads steel failure without lever arm					
$V_{Rk,s,fi,30}$	Characteristic resistance [kN]	0.23	0.61	1.28	2.90
Shear loads, steel failure with lever arm					
$M_{Rk,s,fi,60}$	Characteristic bending resistance [Nm]	0.19	0.66	1.73	5.90

Fire resistance duration = 60 minutes		SS 7.5	SS 10.5	SS 12.5	SS 16.5
Tension loads, steel failure					
$N_{Rk,s,fi,60}$	Characteristic resistance [kN]	0.21	0.53	0.96	2.17
Pull-out failure					
$N_{Rk,p,fi,60}$	Character. resistance in concrete C20/25 to C50/60 [kN]	1.50	2.25	3.00	7.50
Concrete cone failure **)					
$N_{Rk,c,fi,60}$	Character. resistance in concrete C20/25 to C50/60 [kN]	2.06	2.45	3.51	12.35
Shear loads, steel failure without lever arm					
$V_{Rk,s,fi,60}$	Characteristic resistance [kN]	0.21	0.53	0.96	2.17
Shear loads, steel failure with lever arm					
$M_{Rk,s,fi,60}$	Characteristic bending resistance [Nm]	0.17	0.57	1.30	4.42

Fire resistance duration = 90 minutes		SS 7.5	SS 10.5	SS 12.5	SS 16.5
Tension loads, steel failure					
$N_{Rk,s,fi,90}$	Characteristic resistance [kN]	0.16	0.41	0.83	1.88
Pull-out failure					
$N_{Rk,p,fi,90}$	Character. resistance in concrete C20/25 to C50/60 [kN]	1.50	2.25	3.00	7.50
Concrete cone failure **)					
$N_{Rk,c,fi,90}$	Character. resistance in concrete C20/25 to C50/60 [kN]	2.06	2.45	3.51	12.35
Shear loads, steel failure without lever arm					
$V_{Rk,s,fi,90}$	Characteristic resistance [kN]	0.16	0.41	0.83	1.88
Shear loads, steel failure with lever arm					
$M_{Rk,s,fi,90}$	Characteristic bending resistance [Nm]	0.13	0.44	1.13	3.83

Sissy Stud concrete screw

Performances
Characteristic values for fire resistance

Annex D1

English translation prepared by IETcc

Fire resistance duration = 120 minutes		SS 7.5	SS 10.5	SS 12.5	SS 16.5
Tension loads, steel failure					
$N_{Rk,s,fi,120}$	Characteristic resistance [kN]	0.12	0.33	0.64	1.45
Pull-out failure					
$N_{Rk,p,fi,120}$	Character. resistance in concrete C20/25 to C50/60 [kN]	1,20	1.80	2.40	6.00
Concrete cone failure **)					
$N_{Rk,c,fi,120}$	Character. resistance in concrete C20/25 to C50/60 [kN]	1.65	1.96	2.81	9.88
Shear loads, steel failure without lever arm					
$V_{Rk,s,fi,120}$	Characteristic resistance [kN]	0.12	0.33	0.64	1.45
Shear loads, steel failure with lever arm					
$M_{Rk,s,fi,120}$	Characteristic bending resistance [Nm]	0.10	0.35	0.87	2.95

Spacing and edge distances		SS 7.5	SS 10.5	SS 12.5	SS 16.5
$S_{cr,N}$	Spacing [mm]	168	180	208	344
S_{min}	Minimum spacing [mm]	45	50	60	100
$C_{cr,N}$	Edge distance [mm]	84	90	104	172
C_{min}	Minimum edge distance (one side fire) [mm]	84	90	104	172
C_{min}	Minimum edge distance (two sides fire) [mm]	300	300	300	300
γ_{Msp}	Partial safety factor ^{*)} [-]	1.0	1.0	1.0	1.0

*) In absence of other national regulations

**) As a rule, splitting failure can be neglected when cracked concrete and reinforcement is assumed.

Concrete pry-out failure		SS 7.5	SS 10.5	SS 12.5	SS 16.5
k factor	[-]	1	1	1	2

According EN 1992-4:2018, these values of k factor and the relevant values of $N_{Rk,c,fi}$ given in the above tables have to be considered in the design.

Concrete edge failure
The characteristic resistance $V_{Rk,c,fi}^0$ in C20/25 to C50/60 concrete is determined by: $V_{Rk,c,fi}^0 = 0.25 \times V_{Rk,c}^0 (\leq R90)$ and $V_{Rk,c,fi}^0 = 0.20 \times V_{Rk,c}^0 (R120)$ With $V_{Rk,c}^0$ initial value of the characteristic resistance in cracked concrete C20/25 under normal temperature according to EN 1992-4:2018.

Sissy Stud concrete screw	Annex D2
Performances Characteristic values for fire resistance	